

THE ZL2BMI DSB TRANSCEIVER INTRODUCTION

This booklet is designed to help you build a DSB transceiver. It does not contain p.c. board layouts and exact step-by-step instructions to duplicate any of the ten rigs that I have built.

But there are:

- Circuit diagrams
- Construction methods
- An order of construction
- Layouts that have been used
- Lots of helpful notes and comments
- Alternatives from other constructors
- Components and substitutions.

Since building the first transceiver in 1983, there have been letters from a number of amateurs, (including VK's), and some have been motivated to construct some adaption of the original.

The first circuit was published in the Jan/Feb "Break-In", '1984; reading this article will help you to gain some idea of how it all started.

DESIGN PHILOSOPHY

That may sound a grand sub-title, but it is important to realize what I have aimed at and to set your own objectives before you start.

Having only very limited equipment and being quite hopeless at most metalwork, the following were important:

- Small size and light weight (for tramping)
- Simple circuitry
- Battery economy
- 'Voice' transmission (with C.W. if required)
- Ease of construction.

A.M. was feasible, but heavier on battery and not so compatible with S.S.B.

SSB was too complex to produce.

DSB (at low power levels), is simple to produce and economic in terms of battery drain.

1.

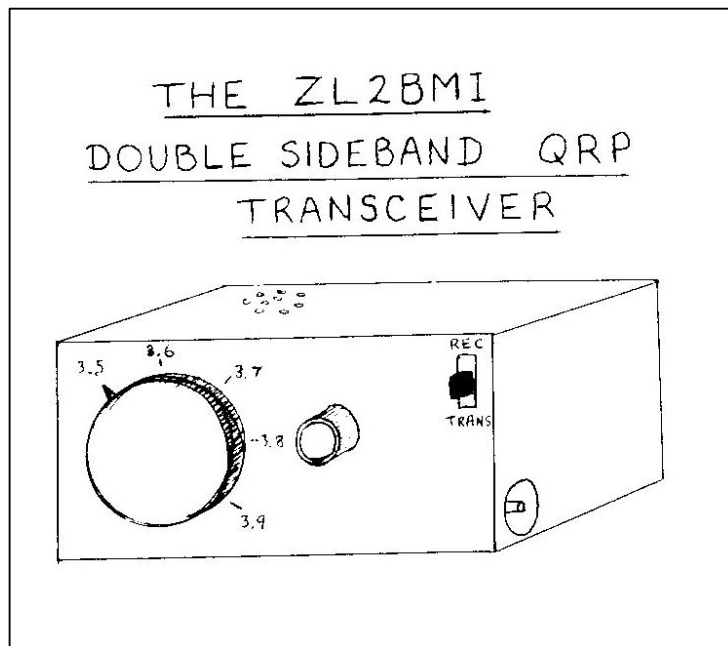

The number '10 rig measures 3 inches X 2 inches X 1¼ inches, puts out 2 watts peak of DSB and has suffered a 4-foot drop onto the chip-board floor of a hut, without damage.

However, developing a rig of this size required a lot of previous construction in order to feel confident about building miniature circuits. Many will not need this type of miniaturization and will find it easier to build on a larger scale. Most home constructors with little experience should at least be able to build a 4" X 4" X 2" rig and have contacts with most parts of N.Z. On a similar rig, ZL3AAO recently worked a VK and received a 5/3 report.

All rigs have been on 80metres, mainly because I find this the best 'all purpose' band; but also because there is plenty of band space available.

It should be noted that because of my interest in QRP for tramping, usually operated well away from civilization, not a great deal of attention has been paid to suppressing harmonics (which are, in any case, of low level in QRP). Simple pi-net filters will suppress these if needed.

HOW IT WAS ACHIEVED

Basically, the first rig just grew.

Realizing that any rig needs an oscillator, a version of the Fred Johnson VFO from Jan/Feb "8reak-In", '1968, was built on a tag strip in a wedding cake tin. To this was added a passive (diode) balanced modulator; then audio from a transistor radio was used to produce an 80m DSB signal, easily copiable on a receiver. With great excitement a carbon mike replaced the 'tranny' and DSB voice was heard.

A chassis was then hastily made from three pieces of copper board and fitted into a 5 inch length of 4inch by 2inch plastic downpipe. A two stage r.f. amplifier then boosted the output to about 1 watt.

The direct conversion receiver proved harder to build than the transmitter, but eventually this was achieved and placed into the chassis. Transmit/receive switching is a simple front-panel switch.

Since the No.1 set, the transmitters have undergone few changes, except in component values. However, the receivers have been altered a number of times; firstly to a better mixer and all-discrete transistor amp; then later to an I/C amp which has proved very good.

Most construction has been on 'copper-pad' boards, made by hacksawing slots in the surface of small pieces. The No.8 rig used a type of 'etched pad' circuit on double-sided p.c. board, but in practice this was much harder to alter than other methods.

At a junk sale, I scored about 10 un-used etched pc boards, each containing about 6 mini-board layouts, including a space for an I/C. These have proved very useful and a diagram will be shown in case you wish to duplicate something similar. Most rigs after No.5 used some of this board for the receiver and even the smallest No.10 rig used it. (Veroboard could be used instead).

At the time of writing 10 rigs have been produced altogether. Of these, 3 have been sold and one is still 'on the shelf' (\$95). Any future rigs for sale will be about \$120 because of the time needed for construction. This price will also encourage more people to build their own!! Each rig is different, which makes it difficult to give exact details of any one rig. Although there was a general progression from larger to smaller rigs, the 4" X 4" X 2" size was found to be the easiest to construct using components that are fairly easily obtainable.

The main problem with very small rigs (like the no. 8 with a touchy vfo), is finding a stable tuning capacitor of small size.

The no.9 rig, although slightly larger than its predecessor, incorporated a switch in the VFO which gave two extra bands below 80m. In a real emergency this rig could be used on the mountain radio frequency.

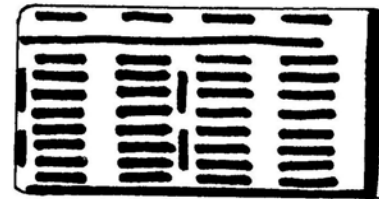

LAYOUT of
mini board
used for
receivers

AN ORDER OF CONSTRUCTION WITH CIRCUITS ADD NOTES.

General

The basic order is: Chassis, VFO, Balanced Modulator, RF amplifier, Receive board.

Mostly I built the VFO before the chassis, so that I could then design the chassis to fit the VFO, but strictly the chassis should be built first.

THE CHASSIS AND CASE

I used either three pieces of copper board or a piece of 26swg roof flashing, to form a U-shaped chassis. This was slid into a short piece of plastic downpipe, either 4"X2" or 2½"x2" cross-section. Find a friendly plumber who can give you short offcuts. Next, mount the switch, pot, and aerial socket, leaving room for the VFO. Drill holes in the back panel for power and mike leads (another for CW socket if needed).

The cases for the smallest sets were made by cutting a piece of 2½"x2" downpipe down the centre, then gluing on a paxolin base (using ADOS F-2)

THE VFO

This is probably the most important part to get right. The coil and tuning capacitor must be as firmly mounted as possible.

At first I used a whole or half wedding cake tin, but these are unavailable now unless you still have a few in your junk box. However, tinfoil from old cans (without ribbing), are easily bent to make a box that can be soldered both inside and outside. Normally, I form the two ends with two adjacent sides, then build the 'inside'. The box is then soldered on to the chassis with one open side down, leaving the larger open side to be covered with a tinfoil cover. At least some point of each side of the cover should be soldered, though not the whole length, otherwise removing the cover is a very difficult job.

The basic circuit is shown in Fig.1, with variations for the use of other value tuning caps.

4.

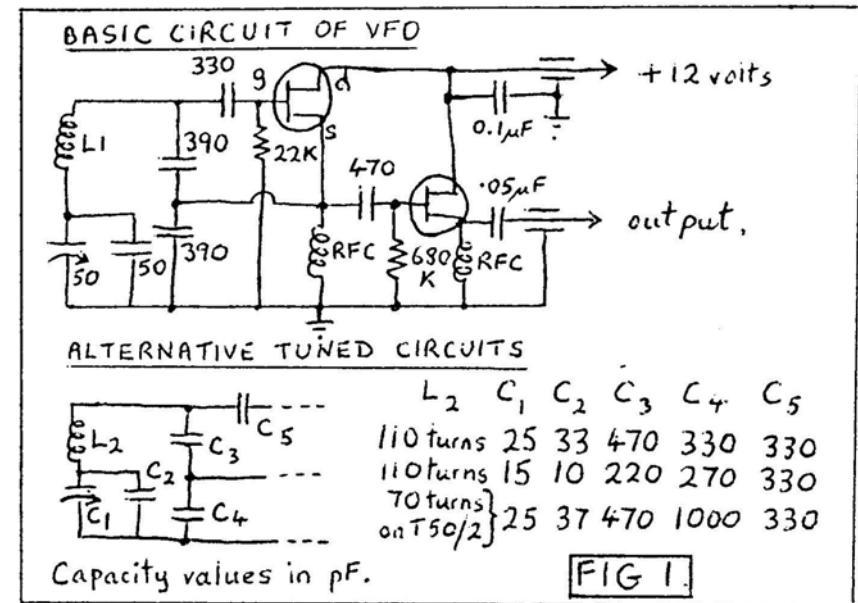

L1, L2 are wound on 5mm slug tuned formers, using about 26swg wire or thinner. These formers are ex miniphones or Pye Cambridges. I think the slug is called an F29. In one alternative case above the coil was wound on a T50/2 toroid.

The tuning cap. and coil are mounted first, using silicone rubber or glue for the coil, then the RFC's and resistors are soldered to the can at appropriate points and used as tie points.

The RFC's used are miniature ferrite-cored types from TV's, about the size of a ¼ watt resistor. Alternatively a ferrite bead can be used with about 8 to 10 turns of wire through it. Also at some point the feedthru's should be mounted on the back wall of the box (these also act as mounting points). Point-to-point wiring, with short leads, is then used for the remaining components. Usually, the oscillator section is got on frequency first, then the buffer stage is added.

The cover will alter the frequency of the VFO, so a hole will need to be drilled for final adjustment of the slug. The VFO is then mounted in the chassis and its output should be about 0.5 to 2 volts.

5.

The FET's originally specified were MPF102's, but these have not been found very reliable. With small value tuning capacitors, the L/C ratio in the tuned circuit may be such that the FET won't oscillate. The solution is to use a higher gain FET such as a J310 or a dual-gate FET with the gates tied together. I got a supply of 2N301's and these are excellent. However these may oscillate so vigorously that they have thermal drift. The classic solution is to add a 1N914 diode from the gate to ground to clip the voltage swing. However this reduces the output markedly, so I found it better to run the VFO on a lower (stabilized) voltage, perhaps down to 3 volts.

The output feedthru' should be a low- or non-capacitive type. DO NOT use the common 1000pF type, or your rf will mostly go to ground. If you can't get feedthrus, just drill a small hole in the can and use a piece of plastic covered wire.

There are two alternative VFO circuits below, one using bipolar transistors, and the other varicap tuning. I have built these but not actually used them in a rig. ZL3AAO has used the varicap tuner.

To avoid 'pulling', the coupling capacitor in the bipolar VFO must be as small as possible. This actually applies to all VFO's.

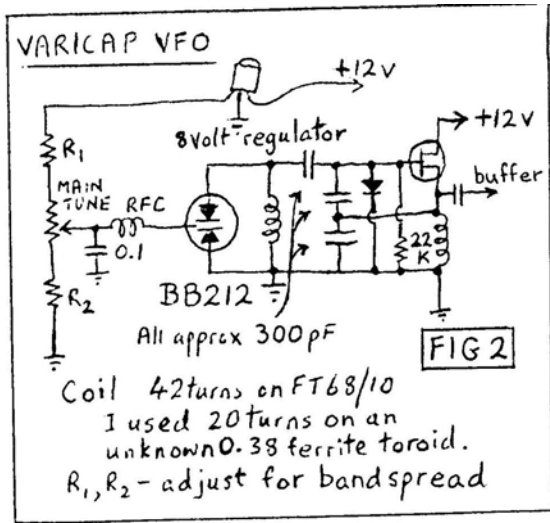

Note:
ALL CAPACITORS IN VFO TUNED CIRCUITS ARE POLYSTYRENE

The- BB212 double varactor diode has a capacity swing of 22-600pF for an 8 volt swing

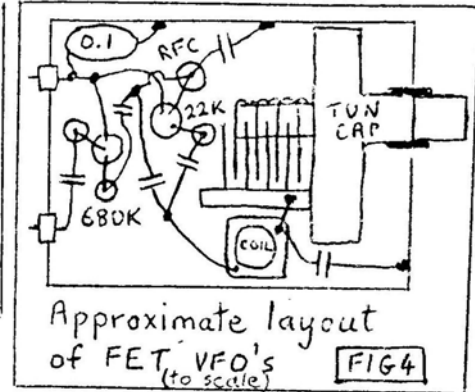
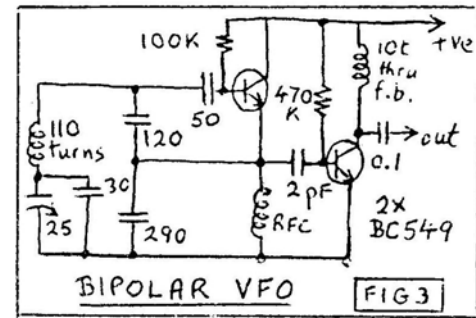

Most VFO's will require some trial of different value capacitors to make the FET oscillate and cover the required band.

Polystyrene capacitors are not easy to obtain, especially in small sizes, but one good source is old B/W TV sets. Don't miss the capacitors which are often found inside the i.f. coils. Silver mica capacitors from this source may also be used, though they may not be so stable, thermally.

The best tuning capacitors are those designed for the job with a proper long shaft. However, many trimmer caps., with short shafts have been used; extending the shafts with 1/4" plastic rod from old pots, using plastic tubing (warmed in hot water), to link them. One source of the right size tubing is old nylon i.f. coil formers from TV's.

Reduction drives make tuning easier, but are not easy to obtain. I did make a ball drive from some bits of copper tubing, brass rod and ball-bearings; however, these need more refinement. Tuning without a reduction drive is not too difficult provided the 80m band covers the whole capacitor swing.

THE BALANCED MODULATOR

Most of these have been built on a small piece of copper board with pads, though one was built on the end of the r.f. amp board and another just point-to-point on the chassis.

T1 must be wound on a ferrite core, usually a toroid of about 0.5" diam. In practice almost ANY core will work; have used a two-hole TV balun core, a cut-down cylindrical TV balun core, and even a ferrite bead with 8 trifilar-wound turns of very fine wire.

My first winding was thin plastic covered wire and this works OK. However, there is better balance if about 26swg wire is twisted together (at least 5 turns per inch), then about 10 turns are wound on the core. It is important to make sure the phasing is correct as in Fig.5. Use enamelled wire.

The diodes are 1N914's, matched as close as possible on a multimeter for forward resistance. The balancing pot. should not exceed 100ohms, and with well matched diodes (or hot carrier diodes), it may be left out altogether, giving more drive to the r.f. amp. (just connect the two diodes together)

The cylindrical TV balun cores were cut in half using a carborundum disk in an electric drill.

The amount of VFO drive to the bal. mod. is fairly critical; approx 0.15 to 0.2 volts (r.f) on most of mine. Firstly, hook a small length of wire as an aerial onto the output of the bal.mod., or loosely connect to a receiver, then try various values of capacitors from the VFO output to ground, until the pot. nulls nicely. This value will depend on the output of the VFO, but will be in the range 15-1500pF. 8.

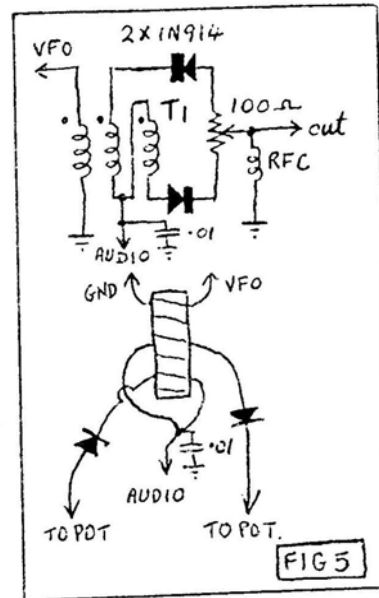

Once the modulator is balancing nicely, take some audio from the earphone socket of a radio or taperecorder, putting one wire to ground and the other to the audio input port of the balanced modulator. Use the radio volume control to adjust the amount of audio and listen on a receiver to the DSB signal. (note- music will sound awful; speech is best). If all is okay, the circuit below using a carbon mike is the simplest way to get a DSB signal of your own voice. However, you may wish to use a more 'modern' mike and amplifier. There are various designs for mike amplifiers in "Solid State Design for the Amateur", p199 and p202, using the 741 op amp, but I have not tried these. Other builders have used a simple one-transistor amp. I have stuck to the carbon mike because of its simplicity.

For testing and adjusting the output of the VFO and bal. mod., I used a cheap SWR meter in the 'field strength' position.

Leads to the toroid and other components should be kept as short as practicable, to avoid stray radiation. Preferably, the modulator should be fully shielded, though I have not done this to any of mine.

The RFC is just 8 – 10 turns through a ferrite bead. An unshielded lead from the VFO to the modulator should be no longer than about half an inch.

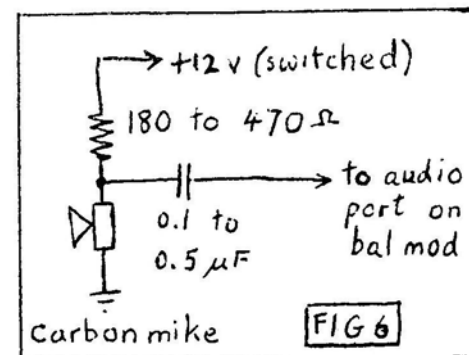

THE R.F. AMPLIFIER.

In all rigs this has consisted of a two stage, broadband amplifier, which is R-C coupled. There are NO tuned circuits. although an 80metre pi-network filter at the output is desirable if the set is to be used regularly in a built-up area.

All except one, have been built on copper-pad boards, usually formed by cutting lines in the copper with the end of a file or mini-hacksaw blade.. A metal straight edge is useful for this.

One of the major objectives is to reduce or stop VHF and other unwanted oscillations, since the gain of the two stages is very high. The copper pad boards, with a ground plane underneath (ie the chassis), have proved very effective in reducing such oscillations. Decoupling of the supply rail with 0.1uF and possibly a 100uF electro is very important. After initially using 2N3053's for the final, a BD139, rated at 8 watts and costing under \$1 was tried with great success. Unlike the 3053's, I have not blown up a BD139.

The first transistor is a BC549 or similar and its associated RFC is about 12 turns through a ferrite bead. The final RFC is a 6-hole ferrite bead with wire thru' all holes. The emitter degeneration resistor in the last stage was necessary to prevent thermal runaway with the 3053's, but was omitted on the No.10 rig, giving greater output. There has been no problem, provided the final collector standing current is about 50mA. This is a class AB stage and current will peak to about 400mA on transmit. The biasing of the final in the No.10 rig was also altered a little. At first, diode bias was tried, but in the end the divider network seemed to work the best.

Make sure that leads on all components are as short as possible.

Sometimes the removal of the aerial or a load, will cause the amp to break into oscillation; even a badly mismatched aerial may cause this. A resistor of about 180 ohms from the aerial side of the output capacitor to ground will often reduce this.

The basic output impedance will be close to 50ohms for the power level being used.

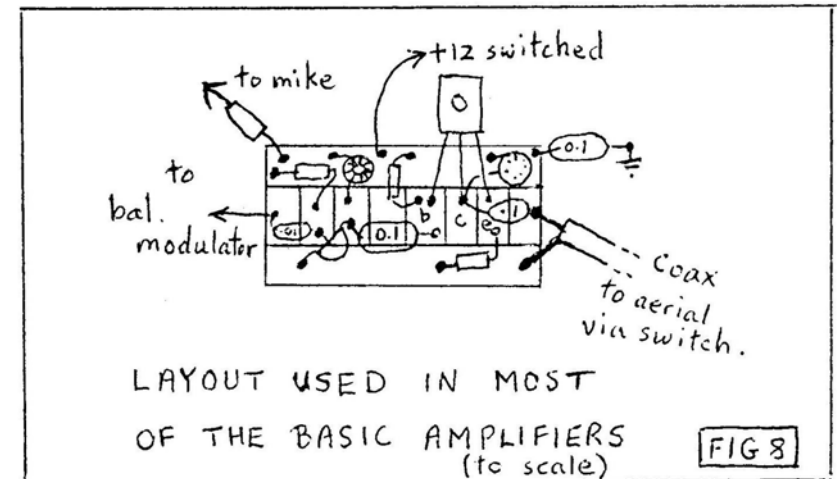
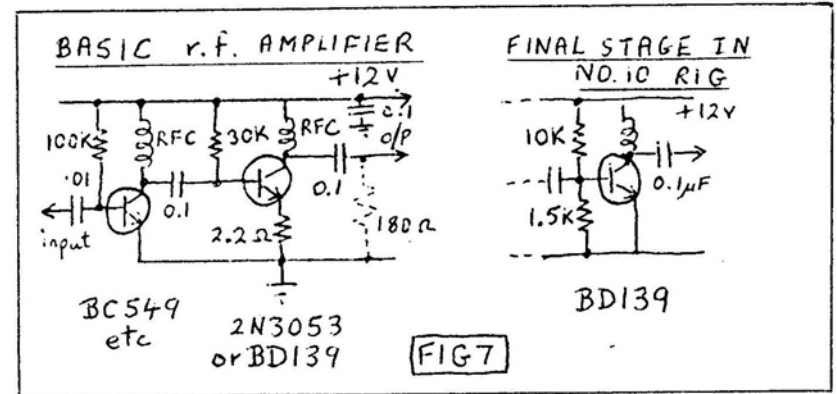

LAYOUT USED IN MOST OF THE BASIC AMPLIFIERS (to scale)

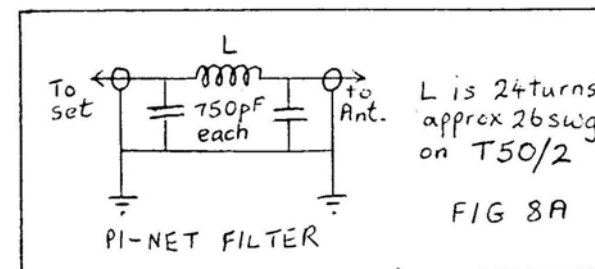

THE RECEIVE BOARD

The receiver has undergone more changes than any other part of the rig, basically because the first one used a lot more components than necessary. I will not discuss that first receiver, but look at the subsequent two and other alternatives.

There are three major parts: the front end, the mixer and a high gain audio amplifier.

After the first rig, the mixer used is a balanced diode mixer, basically the same as the balanced modulator in the transmitter. indeed, one mixer could do both jobs, but because of the complicated switching it is easier to use separate units.

The front end is a very simple r.f. gain control, with the input winding of the mixer tuned to 80metres in the No 2 to 7 rigs. When an r.f. amplifier stage was added to the later receivers, it became necessary to add a simple tuned circuit to the front end.

The second receiver used all discrete transistors, with an output Darlington pair configured for a low impedance output. An 8 ohm speaker will not give such good results as a higher impedance telephone earpiece in this circuit. There is very high gain, so bypassing of the supply rail is important. I no longer use this circuit (Fig.9), but include it in case you wish to try it

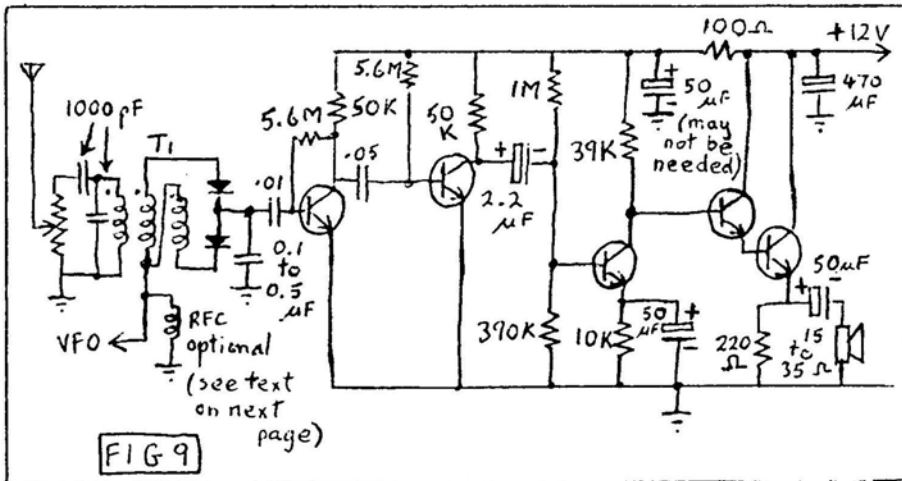

12

The remarkable little circuit opposite in Fig.10

is about as simple as possible. Although the audio was slightly distorted, it gave quite good loudspeaker volume even of weak VK's. The speaker is a 600 ohm version, ex-TV. Attempts to make a similar circuit with low impedance output were not successful.

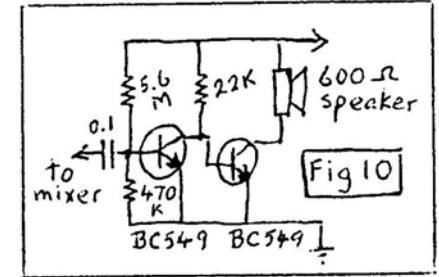

However, the basic circuit used now has as its heart the LM386N audio amp I/C. This has a gain of up to 46dB, and some rigs have been built using just the I/C alone for the receiver gain. For more gain, I added a transistor and this is the circuit shown in Fig.11.

T1 is a trifilar winding on a small ferrite core, being careful of phasing (see balanced modulator). The input capacitors should be adjusted to resonate on 80m with the primary winding of T1. The RFC shown is not necessary if a transmitter is connected (more about this later).

The .033uf capacitor is very necessary to prevent audio oscillation, but may be varied in value to give as much gain as possible.

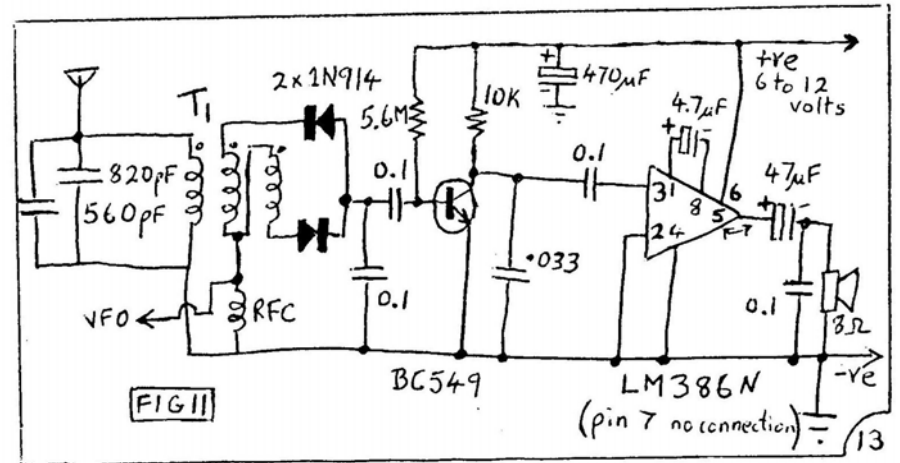

13

Finally, an r.f.amp was added to the front end raising even the weakest signals to excellent loud-speaker volume. Spurious signals were also increased, making some sort of tuned front end necessary. Basically any coil (toroidal or not) and capacitor, resonant on the desired band, may be used.

The basic circuit is shown in Fig.12, but the front end should be optimized depending on the coil you are using. No layout will be shown for the receivers, since they are all different. However, remember the LM386 has very high gain and must have short leads (especially on pin 3), as well as good bypassing, to avoid trouble. It should draw 5-10mA, under quiescent conditions. If it oscillates (possibly at a supersonic frequency) the gain will be markedly reduced. The 0.1uf capacitor shown 'across' the speaker may actually go from pin 5 to ground and in any event must be close to the output of the I/C.

The diodes in all receivers are 1N914's matched on an ohm-meter. The transistors are BC549 etc.

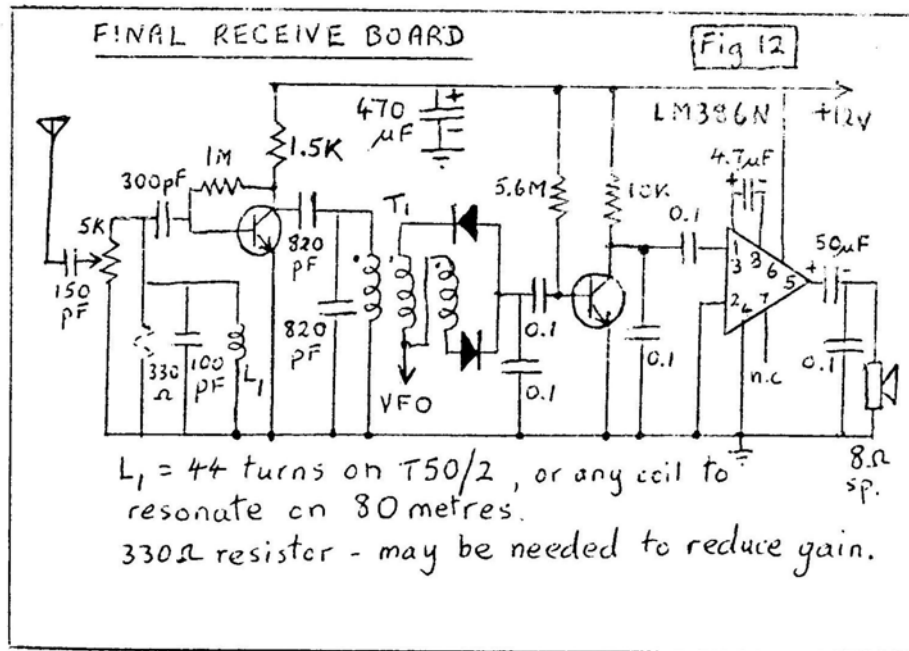

OTHER NOTES

The RFC shown on the receive boards is to provide a d.c. path and is not necessary in a complete transceiver, since the primary of the balanced mod. coil fulfils this purpose.

The transmit/receive switch switches +12V to r.f.amp board/mike circuit on transmit and to receive board on receive and is also used for aerial switching.

The VFO is running all the time and remains connected to both bal. mod and receive boards. Final adjustment to the VFO injection level can be made when the whole set is assembled.

The receiver sensitivity will suffer with an out of tune aerial; best to use a dipole.

CW can be easily achieved by applying +12V to the audio port of the balanced modulator, through a 1000 ohm resistor. The output of the transmitter should be about 1 – 2 watts PEP on DSB, and more than 2 watts on CW.

The basic idea is to EXPERIMENT as much as possible.

Many of the components are available from Dick Smith stores. Toroids are almost unobtainable so try not to use them! Some very miniature speakers are obtainable from South Island Components, Christchurch.

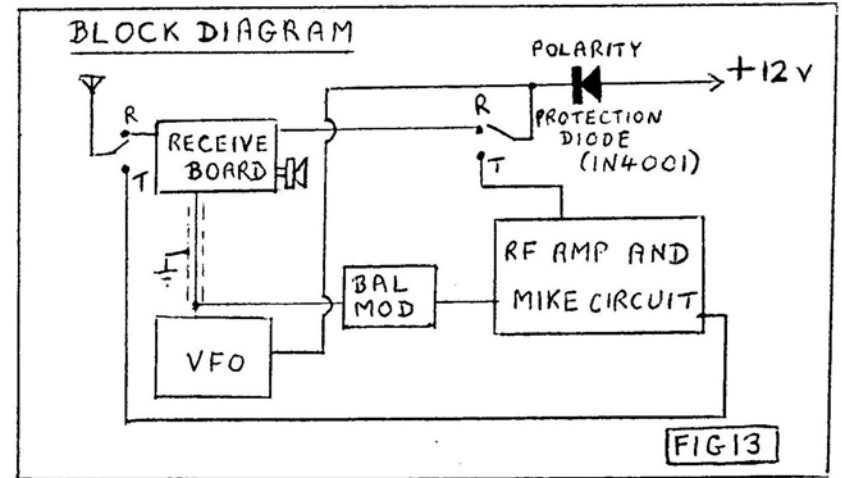

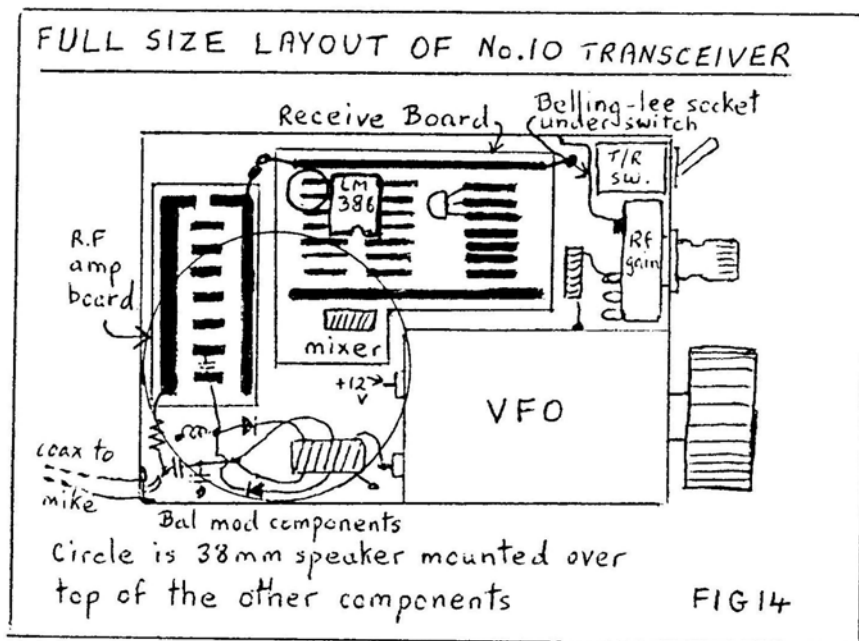

Most rigs are just larger versions of the above, usually to the same sort of layout.

Note that thin audio coax is used on the mike AND for r.f. runs. For 80 meters, short lengths of this coax are quite suitable, and are much cheaper than RG174/U, if you can get it.

Don't forget to put in a 1N4001 protection diode in the power circuit, even when experimenting; it saves a lot of transistors!

Best of luck with the experimenting.

'73s from ERIC SEARS ZL2BMI